

7FC CLEANABLE COLD CATHODE SENSOR

Double Inverted Magnetron Technology

Usable Range: 1×10^{-2} to 1×10^{-11} Torr

Product Features

- **Robust Construction:** All wetted materials are 304 stainless. Metal-sealed / cleanable subassembly can be maintained without breaking the primary vacuum interface.
- **UHV Compatible:** Knife edge seals and 10^{-11} std. cc/sec. (He) leak rate ensure reliable ultra high vacuum operation.
- **Small Size:** Compact design permits easy replacement of older obsolete sensors.
- **Versatile:** Use in any physical orientation.
- **Rugged:** Withstands frequent pressure bursts. No hot filaments to sag and break.
- **Reliable Service:** Simple design means years of productive use in difficult applications.
- **Bakeable to 200 degrees C.**



PRODUCT DESCRIPTION

The Televac model 7FC employs patented¹ Double Inverted Magnetron sensor technology to create a rugged and robust wide range vacuum sensor. Unlike most high or ultra high vacuum sensors that have a few decades of dynamic range, the 7FC gives its user ten (10) decades of useful range when used with a mating Televac controller. Typical UHV sensors cannot be disassembled in the field for cleaning. The 7FC's cleanable sub-assembly can be removed for cleaning without having to break the primary vacuum seal. Unlike hot filament sensors that won't tolerate large pressure bursts without compromising its filament, the 7FC will sustain and automatically recover from large pressure bursts.

¹United States Patent No. 5568053

PRODUCT APPLICATIONS

- CRT Mfg.
- Deposition of Optical & Functional Films
- Distillation of Low Vapor Pressure Chemicals
- Electron Microscopes
- Freeze Drying
- Helium Mass Spec. Leak Detectors
- High Energy Physics
- Lamp, Lighting & Laser Products Mfg.
- Mass Spectrometers
- Metallurgical Processes
- Night Vision / Electro-Optical Detector Mfg.
- Plasma Enhanced Deposition
- Sterilization

PRODUCT SPECIFICATIONS

- Range: 1×10^{-2} to 1×10^{-11} Torr
- Overpressure Tolerance: 150 PSIG
- Wetted Materials: Type 304 Stainless Steel
- Operating Temperature Range: +15 C to +50 C
- Maximum Continuous Bake Temperature: +200C
- Calibrated Medium: Dry Nitrogen per AVS Recommended Practice No. 6.4-1969
- Vacuum Interface: 2.75" CF Non-Rotatable Flange

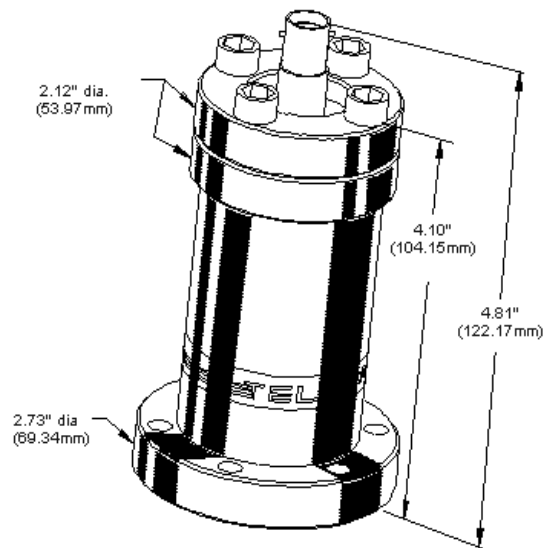

ORDERING INFORMATION

Sensor Part Number: 2-2146-052

Recommended Controllers:

MM200, Part Number 2-7900-20 (base unit) + 2-6200-245 (7F module)

MC300, Part Number 2-4502-303 or 304 (see note below)

Cables are available in several standard lengths as well as custom lengths:

Standard cable -

10' - Part Number: 2-9841-10

20' - Part Number: 2-9841-20

35' - Part Number: 2-9841-35

50' - Part Number: 2-9841-50

High temperature cable (200 C) -

10' - Part Number: 2-9842-10

20' - Part Number: 2-9842-20

35' - Part Number: 2-9842-35

50' - Part Number: 2-9842-50

Triaxial cables for 10^{-11} Torr readings & electrical noise immunity -

10' - Part Number: 2-9835-10

20' - Part Number: 2-9835-20

35' - Part Number: 2-9835-35

40' - Part Number: 2-9835-40

Standard and gold coated vacuum seals quoted upon request

A Division of The Fredericks Company
2400 Philmont Avenue
Huntingdon Valley, PA 19006-0067
Phone - 215.947.2500
Fax - 215.947.7464
www.televac.com

TELEVAC